



FOLDING DOORS

Our hot-dip galvanised folding doors are well-known for their strength and the many options available with respect to design.



Built to last.®



DOORS THAT LAST

EAB's hand-operated and machine-operated folding doors are made of hot-dip galvanised steel. They are made according to very high standards thanks to a quality approach and professional expertise that permeates the entire chain, from design and delivery to installation. Our doors have a consistently high finish and a highly robust construction.

Each folding door is manufactured in Smålandsstenar. Entirely according to your wishes. Choose between 2, 3, 4 or 6 section doors, either inward or outward opening. With or without machine operation. In terms of design, there is a lot of freedom of choice. Whether genuinely rustic in style or stylishly modern, we offer customised solutions to suit your business. These advantages have made our folding doors for industry a natural first choice, even on architects' drawings.



ROBUST DESIGN

EAB's industrial doors have heavy-duty fittings, a high quality finish and a robust construction with few moving parts. This gives the door superior durability with minimum maintenance. The door remains intact, despite harsh weather conditions.

FEATURES

EAB's folding doors can be designed for manual operation or proven machine operation. The combination of robust construction, welded details and skilled craftsmen makes it possible to get doors for your business with the right features and that last.

10 YEAR GUARANTEE

We know that our doors will last and that they keep our promises. Therefore, a 10-year guarantee is always included regardless of the solution you choose. Each door is manufactured in our own factory in Smålandsstenar.



Let the light in with fully glazed doors, in a colour that matches the façade. 4-section folding door with access door.



Fully glazed 4-section folding door in black with machine operation.



Folding door with dark grey painted sheet metal, 4-section and outward opening.

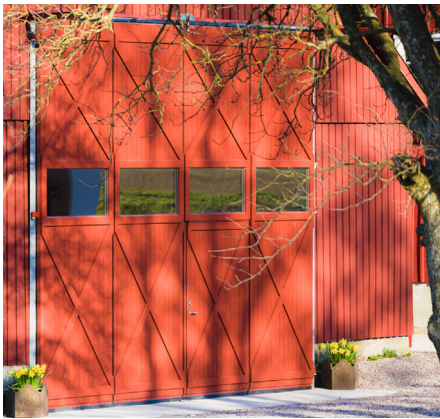

Wood-clad 4section folding door with classic crosses and a row of glazing.



Silver enamelled steel sheet, 4 section, folding doors with two rows of glazing.



Folding door, 4 section, with three rows of glass and grates on the inside.

CUSTOMISE YOUR DOOR

At EAB we create concrete proof every day that a durable and functional door need not boring. With 60 years' experience in door manufacturing, we know the art of combining design, function and durability. The options for customising your door are endless.

All our doors are hot-dip galvanised in their basic version and there are several different surface treatment options available, depending on the environment in which the door is placed. Choose lacquered sheet metal as cladding, a fully glazed door that lets in natural light, or a wood-clad door for a more rustic feel. The colour and cladding are entirely up to you.

Would you like to find out more about our folding doors, the associated service packages and how you can customise your own door? Scan the QR code or visit www.eab.info/folding-door



STANDARD COLOURS

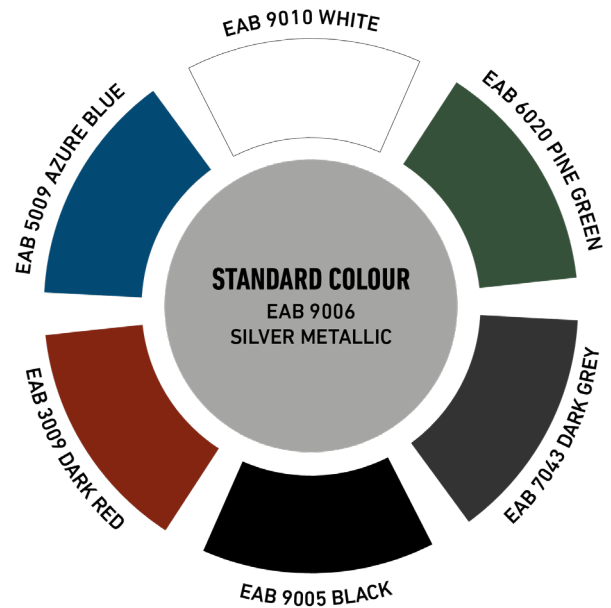

FACTS

Design

EAB's steel folding doors are frame-built, can withstand rough handling and are easy to realign. They are manufactured with 2, 3, 4 or 6 sections with either manual or motor-operated.

Door leaf

Frame of hot-dip galvanised square tubes. Clad inside and outside with silver lacquered EAB profiled steel sheet 9006 in the basic design, or coated with any EAB standard colour.

Insulation

We offer three insulation options: uninsulated, intermediate insulation of 40 or alternatively 60 mm mineral wool, density 80 kg/m³ and thermal.

Glazing

The doors are supplied with insulating glass D4-18, that has a U value of 1.1, mounted in heavy-duty strips of natural anodised aluminium.

Fittings

- Lubrication-free and welded hinges
- Ball bearing guide fittings or carrier fittings that run in C-profiles
- Guide lug on floor in the door centre.
- Internal locking with espagnolettes, DEJO 55100
- The espagnolettes are fitted with eyelets for padlocks
- The doors can advantageously be fitted with an access door and standard lock Assa 410-50 (class 3) excluding cylinder and lever door handle 640 N. Security pins and safety lock plates are included.

Frame

EAB manufactures and stocks U and L profile frames and square tubes.

Surface treatment

Option 1: Hot-dip galvanised door leaf frame clad internally and externally with silver lacquered EAB profiled steel sheet 9006.

Option 2: Hot dip galvanised door leaf frame with polyester lacquered steel sheet cladding as per the separate range of colours.

Option 3: Paint treatment on hot-dip galvanised door leaf frame and sheet metal cladding is available in any NCS colour.

CE marking

EAB's doors are CE marked in accordance with the Construction Product Regulation and the Machine Safety Directive. Meets the requirements of the EN 13241-1 door standard.

Carrier fitting

Over 4.5m door width

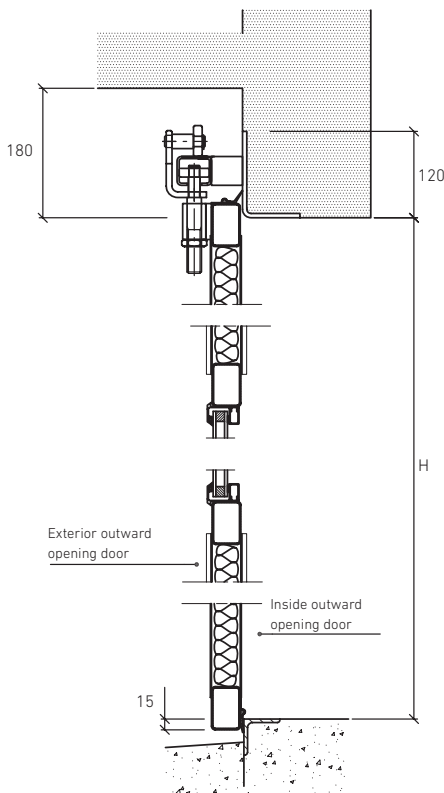

Guide fitting

Up to 4.5 m door width

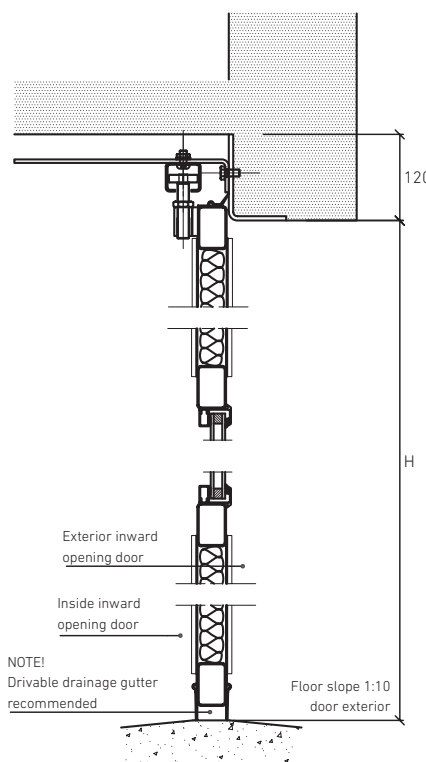

Threshold strip

Applies to outward opening doors

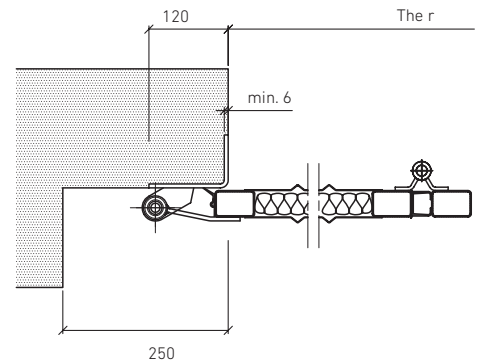

Built to last.®

STORAGE EQUIPMENT | DOORS | STEEL BUILDINGS
333 33 SMÅLANDSSTENAR | +46 371 340 00 | WWW.EAB.INFO

