



ENTRANCES

Thanks to their robust construction, EAB's entryways and glass partitions are highly durable in all types of environments.



Built to last.®



ENTRANCES AND GLASS SECTIONS

EAB's entrances, doors and steel sections are made in a flexible and stable profile system with smooth inner and outer sides and no visible joints. Cutting and installation takes place with great accuracy.

There are several options for adapting the dimensions and customising your entrance area to fully suit your needs and requirements. In addition to full or partial glass entrances, you can also choose to have them pre-painted in an NCS or RAL colour of your choice, which aesthetically fits both the building and your business.

Thanks to their robust construction, EAB's entrance partitions and glass partitions are highly durable in all kinds of environments. We manufacture your glass partition or entrance partition according to your specific needs and requirements, thus giving you freedom to choose dimensions, colour and glass.



ROBUST DESIGN

EABS entrance sections, door sections and glass sections are made in a robust and flexible profile system, which makes them strong and durable. This flexibility combines function and design, which provides a wide range of opportunities when it comes to aesthetic choices, wants and adaptations.

STYLE THAT LASTS

The combination of a flexible profile system, a wealth of knowledge about steel, welded details and skilled craftsmen make it possible to get solid and elegant entrance, door and glass sections that last. We offer customised solutions for your business.

10 YEAR GUARANTEE

We know that our doors last. That's why they always come with a 10-year guarantee, regardless of which the solution you choose.



Glass entrance door.



White lacquered entrance door with glazed section.



Glass entrance with grey lacquered steel frames, natural light transmission.



Entrance with white lacquered steel frame.



Steel door with light transmission at the top, lacquered in red.



Glazed entrance section lacquered in a pleasant shade of green.

CUSTOMISE YOUR ENTRANCE

The possibilities for adapting your entryway are endless. Build your entrance according to your wants and needs, thus creating something truly exceptional. The colour of the entrance can change the appearance of the entire building. We are aware of that and you can choose the NCS or RAL colour that suits you and your company.

Since the beginning of the 1970's, EAB has manufactured doors for industrial, agricultural, public and private environments and for many other companies. Over time, our range has gained considerable breadth. Entrance doors and steel sections are a work of craftsmanship, even down to the smallest detail, which requires a great deal of experience, sensitivity and precision.

Would you like to find out more about our entrance areas and how you can adapt your own entrance? Scan the QR code or go to www.eab.info/entrances



FACTS

EAB's entrances, doors and steel sections are made in a flexible and stable profile system with smooth inner and outer sides and no visible joints. Cutting and installation takes place with great accuracy.

Design

Every entrance, door and steel section that we deliver is unique and manufactured according to drawings approved by our customers.

Surface treatment

Sandblasting, priming and final painting with two-component wet coating.

The number of paint layers is governed by your environmental classification requirements.

The surface smoothness for every visible weld joint is checked.

Glazing

According to applicable classification requirements.

Locks and other fittings

As requested.

Security requirements

EAB's entrances, doors and sections meet all Swedish building standard requirements and are type-approved by RISE for fire and burglary protection.

Our products can be manufactured in safety classes in accordance with SS-EN 1627. Fire class up to EI-90

provides effective fire protection for at least 90 minutes.

Delivery and assembly

Comes with detailed instructions for self-installation. Installation can also be carried out by EAB's service and installation staff.

EAB Built to last

Sustainability is a hallmark of EAB. Our accuracy and our quality approach are included in everything from material selection to manufacturing, delivery and assembly. Sustainability also includes the relationships we have with our customers, suppliers and employees.

A SELECTION OF OUR STEEL PROFILES

Profiles with a thermal break in the cold bridge

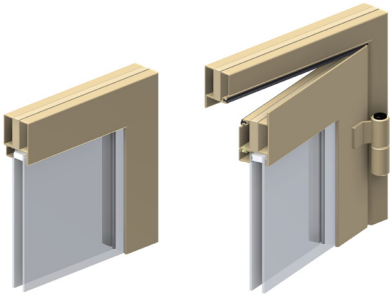

Cut in glazed wall section

Cut in glazed wall section

Insulated profiles in fire class EI-30/EI60, apply to interior door installation

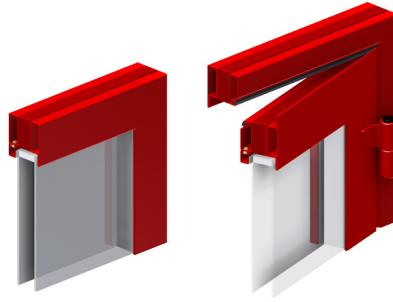

Cut in glazed wall section

Cut in glazed wall section

Uninsulated/fire-classified profiles E-30/E-60, apply to internal door assembly

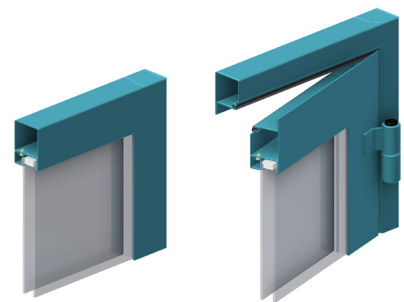

Cut in glazed wall section

Cut in glazed wall section

Insulated fire-classified profiles for wall/window sections

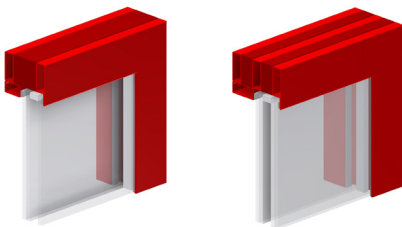

Cut in glazed wall section EI-60

Cut in glazed wall section EI-90

Clamp-free rear edge

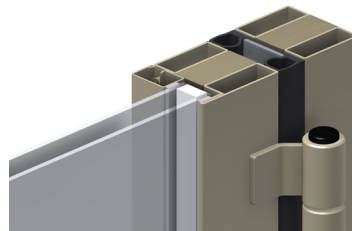

Built to last.*

STORAGE EQUIPMENT | DOORS | STEEL BUILDINGS
333 33 SMÅLANDSSTENAR | +46 371 340 00 | WWW.EAB.INFO

